



# RECOMENDACIONES

Recommandations - Consigli - Recomendações -  
Aanbevelingen - Empfehlungen

---

- ES** Los tacos y tornillos incluidos no son aptos para paredes de pladur.
- EN** The included plugs and screws are not suitable for drywall.
- DE** Die mitgelieferten Dübel und Schrauben sind nicht für Gipswände geeignet.
- FR** Les chevilles et les vis fournies ne conviennent pas aux murs en placoplâtre.
- IT** I tasselli e le viti in dotazione non sono adatti alle pareti in cartongesso.
- NL** De meegeleverde pluggen en schroeven zijn niet geschikt voor gipswanden.
- PT** As buchas e os parafusos incluídos não são adequados para paredes de pladur.

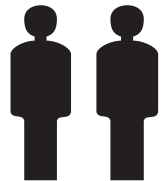
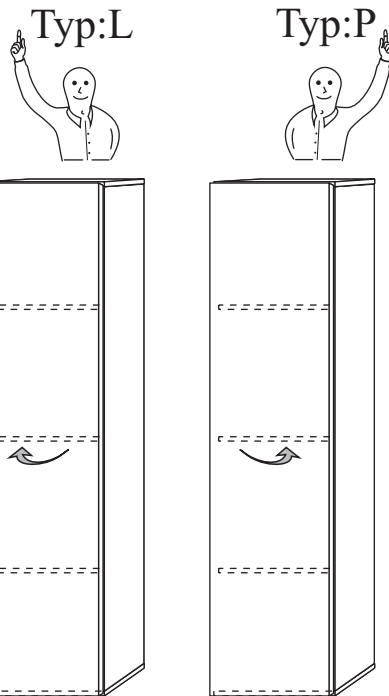

**2 Personen  
2 Osoby**

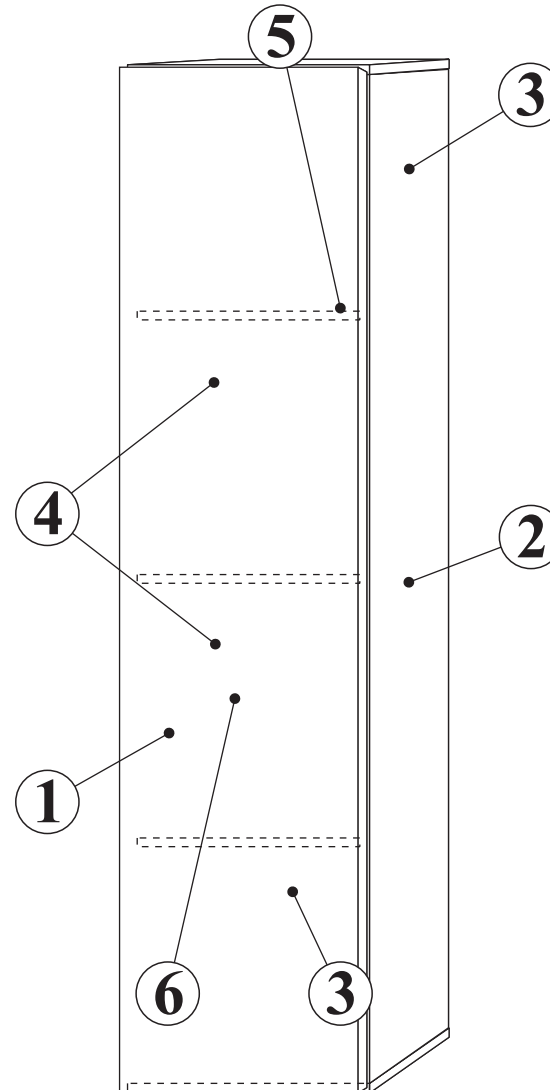

### Pflegehinweis!

Bitte nur mit einem Staubtuch oder einem feuchten Lappen reinigen.

**KEINE** scheuernde Putzmittel verwenden!

### Wskazówka dotycząca pielęgnacji!

Proszę czyścić tylko suchą lub lekko wilgotną szmatką do kurzu. Nie używać żadnych środków szorstkich!

Max. zulässige Belastungen  
von Einlegeböden in kg:

Maksymalne obciążenie półek w kg:

Stärke/Gr.	Spanplatte/Plyta		
Länge/Dł. mm	15	18	22
0<400			
401<600	40	40	40
601<800	24		
801<1000	15	30	

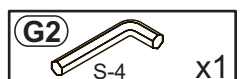
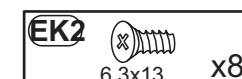
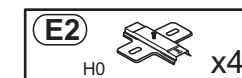
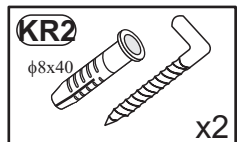
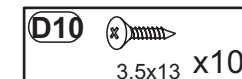
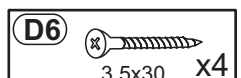
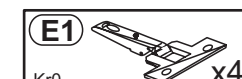
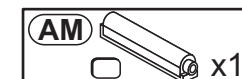
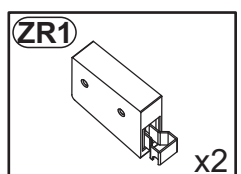
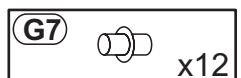
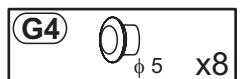
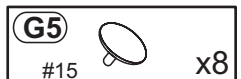
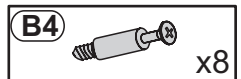
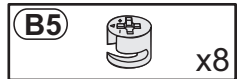
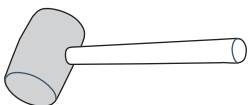
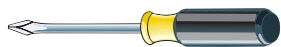
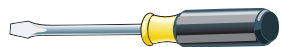
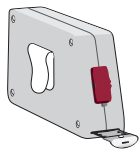

# 1

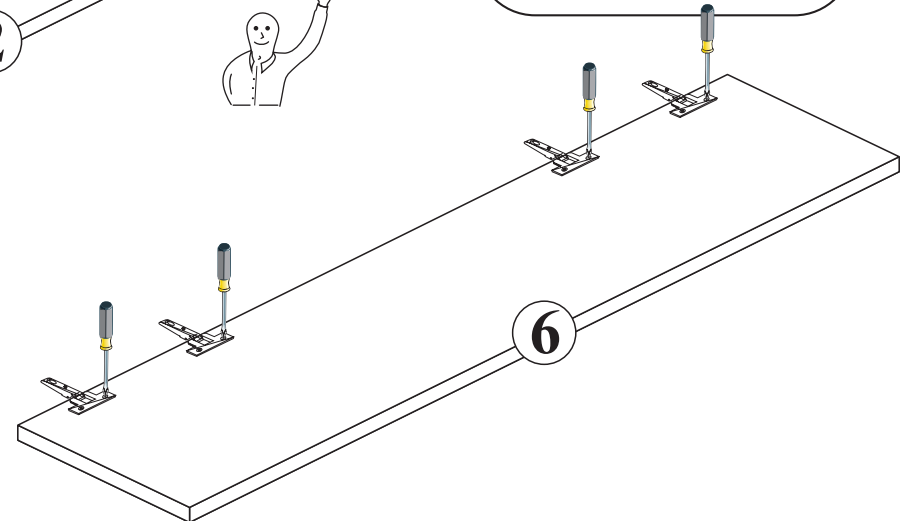
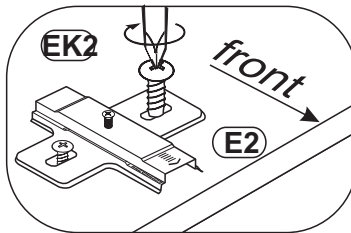
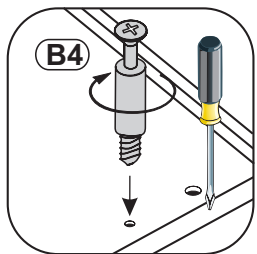
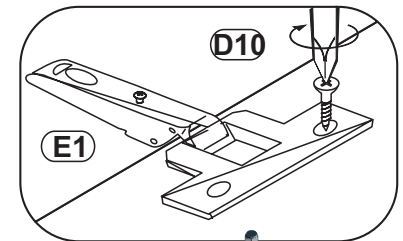
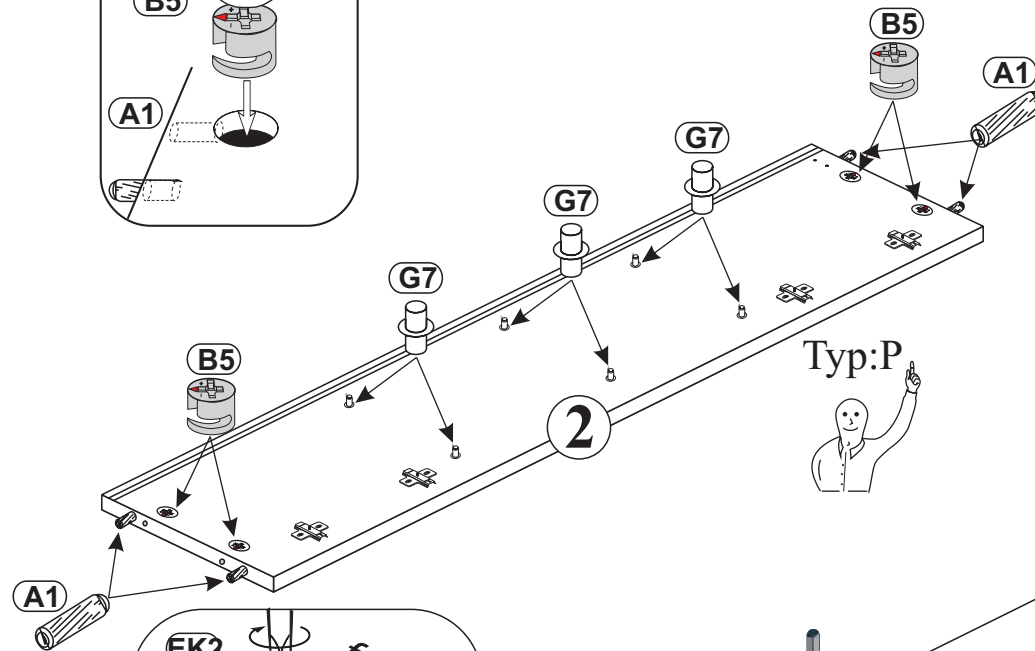
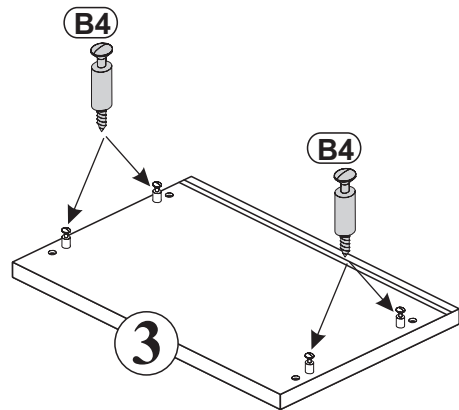
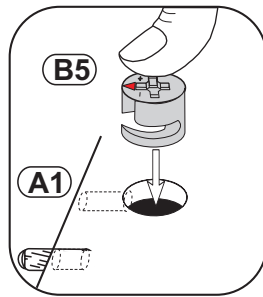
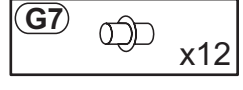
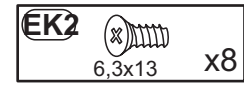
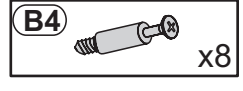
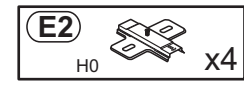
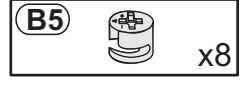
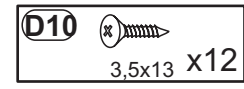
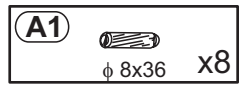
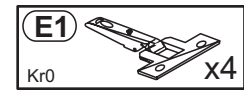
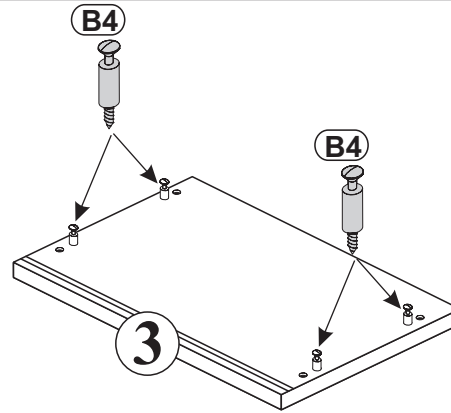
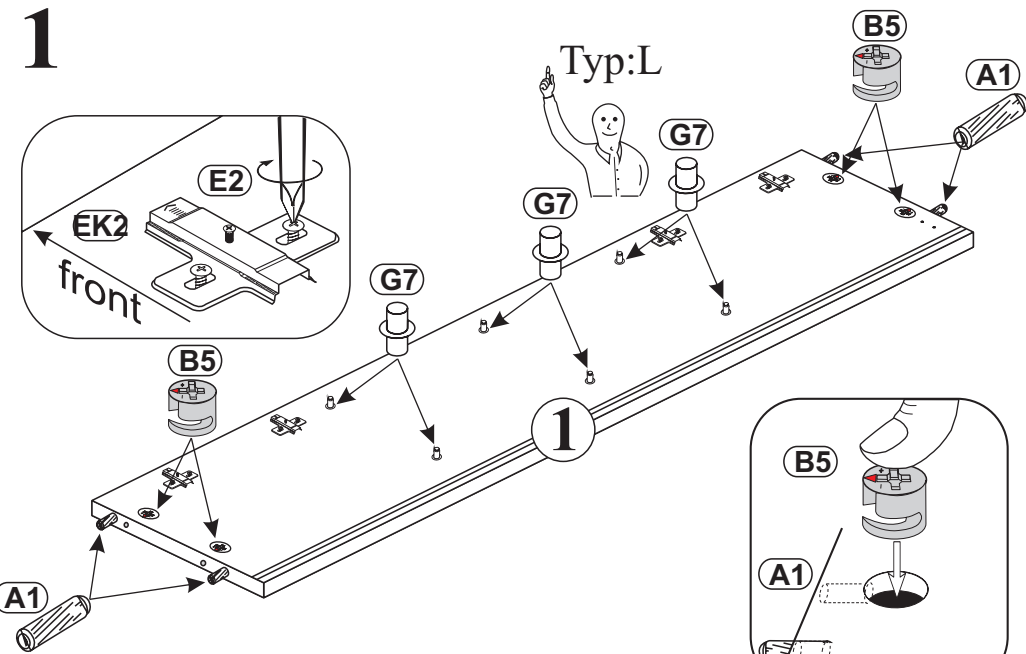

2

Typ:L

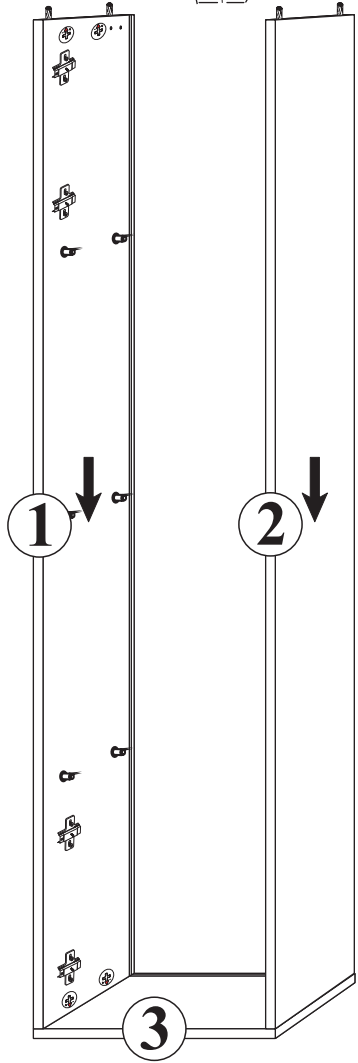

Typ:P

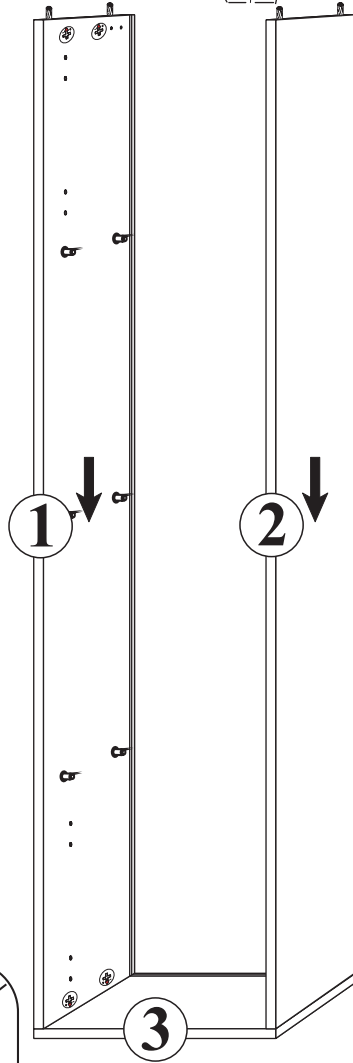

3

Typ:L

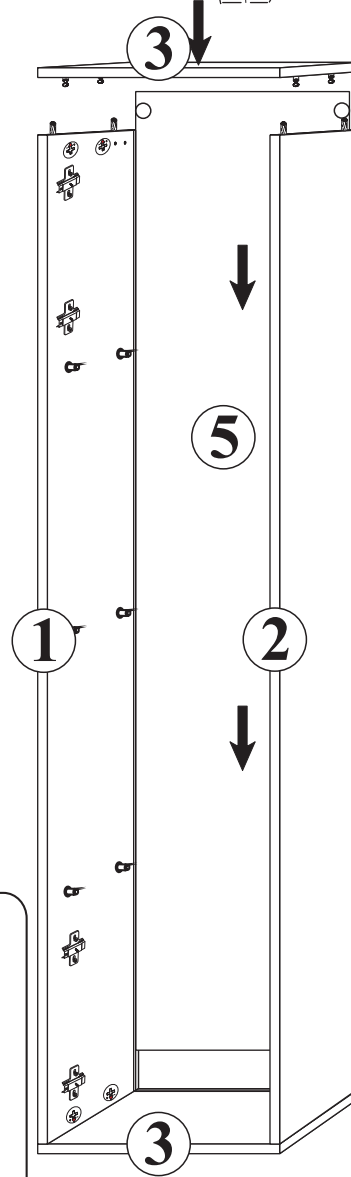

Typ:P

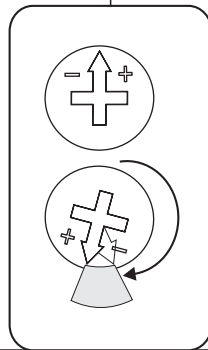
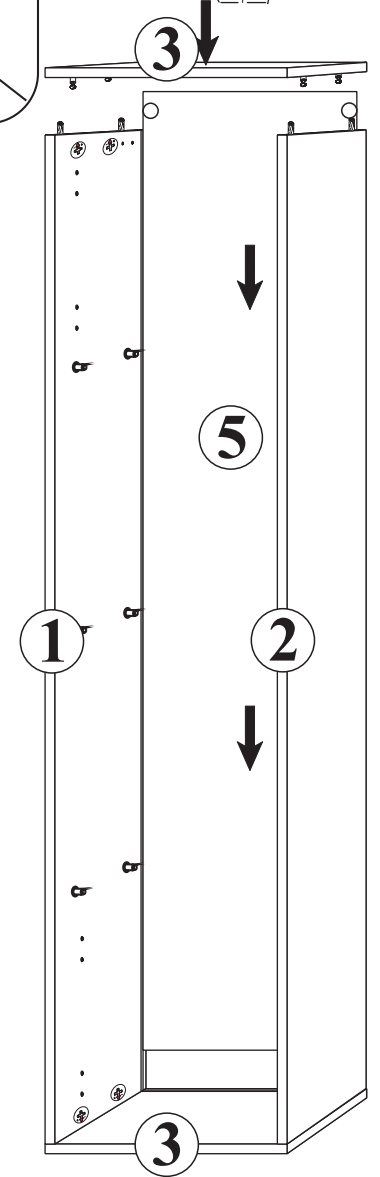

4

S1  x12

a=b

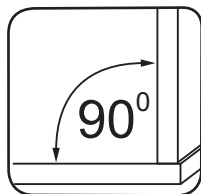
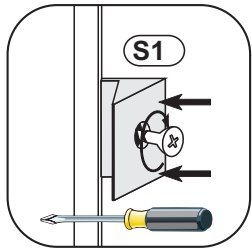
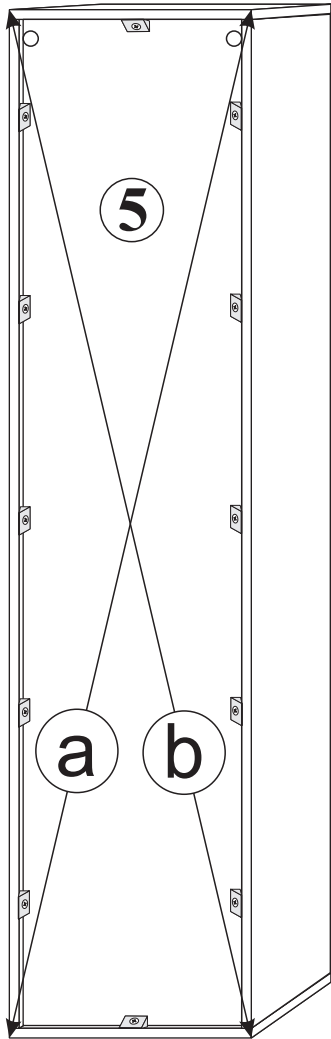

5

Typ:L

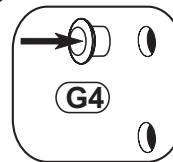
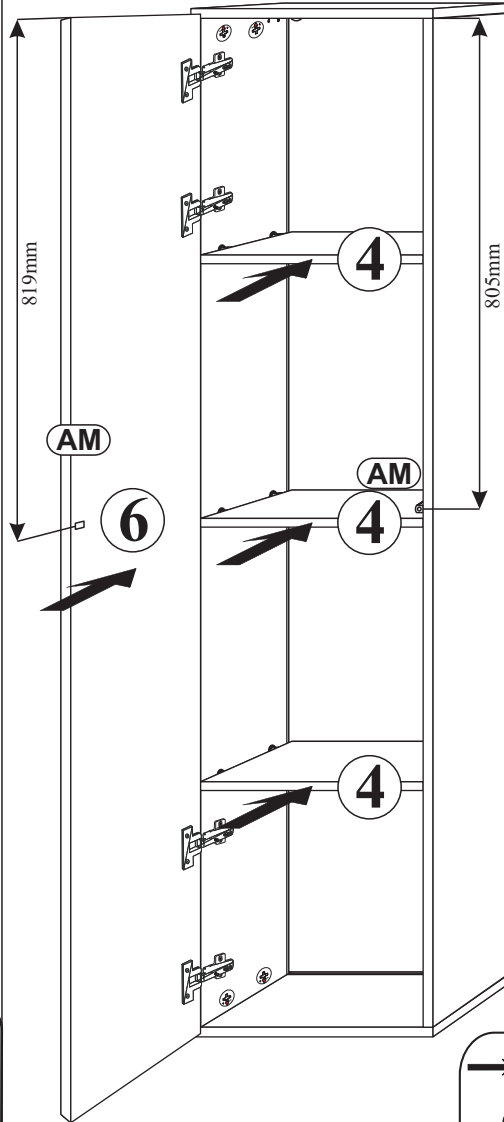

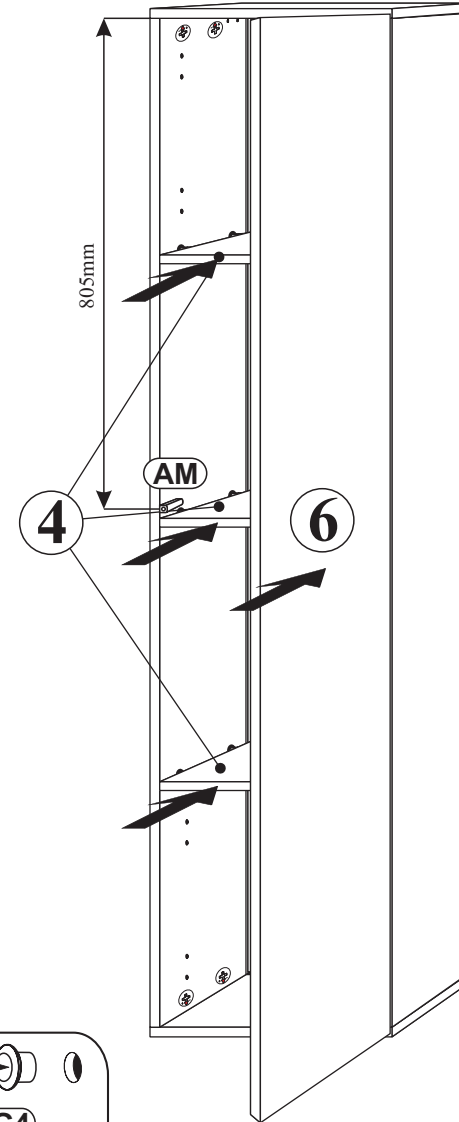

Typ:P

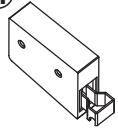

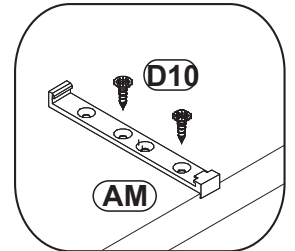
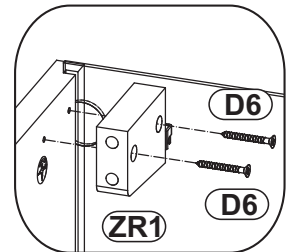
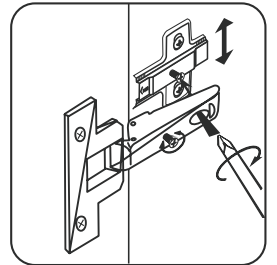

ZR1  x2

D6  3,5x30 x4

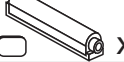

D10  3,5x13 x2

AM  x1

G4   $\phi$  5 x8

6

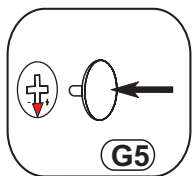
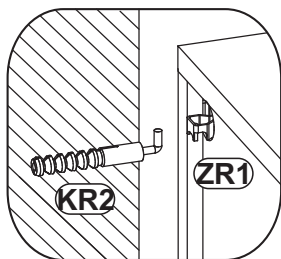
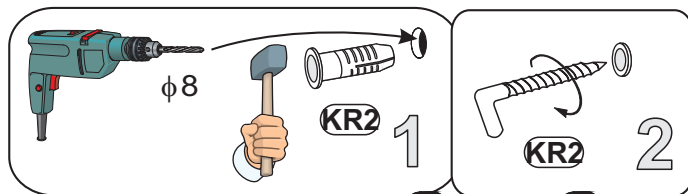

**PL** Złączone kolki do zawieszania bryły, do stosowania wyłącznie do ścian betonowych, do innych ścian należy odpowiednio dokupić.

**D** Die beigefügten Dübel zum Aufhängen des Elements dürfen nur bei Betonwänden eingesetzt werden, bei anderen Wandarten müssen entsprechende Dübel zugekauft werden.

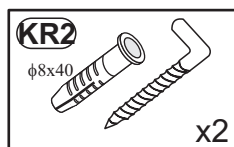
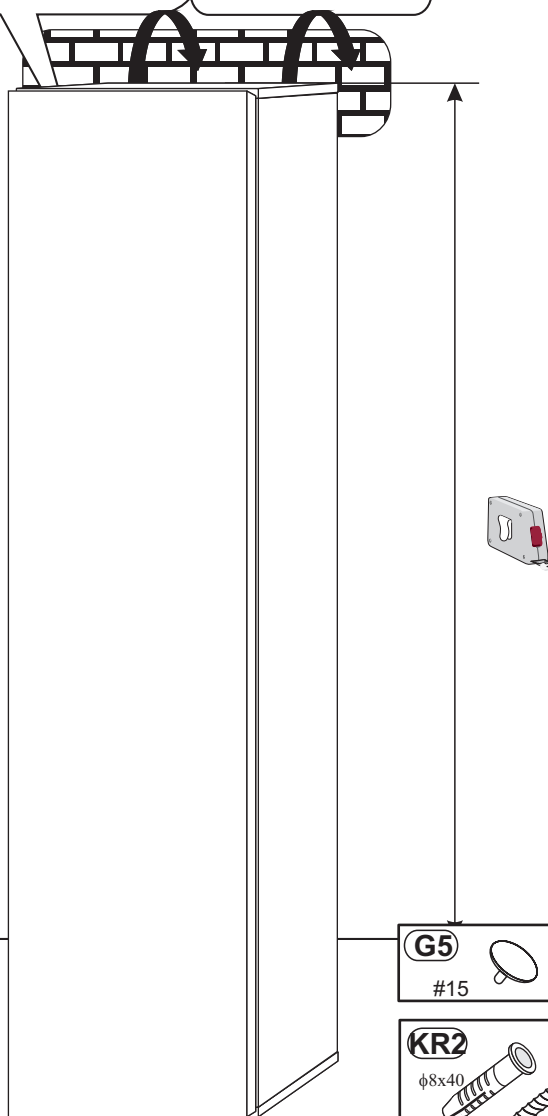

## Verstellmöglichkeiten

- a) Fugenverstellung:  
Befestigungsschraube "A" lockern, gewünschte Fuge mit Schraube "B" einstellen, Schraube "A" anziehen.
- b) Tiefenverstellung:  
Befestigungsschraube "A" lockern, Bandarm nach vorne oder rückwärts verschieben, Schraube "A" anziehen, Schraube "B" mit einer 1/4 Drehung nach rechts arretieren.
- c) Höhenverstellung:  
Befestigungsschraube "C" lockern, Höhe einstellen, Schraube "C" anziehen.

## Instructions for hinge adjustment

- a) Side adjustment:  
Loosen fixing screw "A", adjust gap with screw "B" and retighten screw "A".
- b) Depth adjustment:  
Loosen fixing screw "A", push hinge arm forwards or backwards, retighten screw "A", fix screw "B" with a 1/4-turn in clock-wise direction.
- c) Height adjustment:  
Loosen screw "C", adjust height, retighten screw "C".

## Les possibilités de positionnement

- a) Positionnement de la rainure:  
Desserrer la vis de fixation "A", positionner avec la vis "B" la rainure (joint) souhaitée et resserrer la vis "A".
- b) Positionnement de la profondeur:  
Desserrer la vis de fixation "A" (1 tour), régler la profondeur et resserrer la vis "A".
- c) Positionnement de la hauteur:  
Desserrer la vis de fixation "C" (1 tour), positionner la hauteur et resserrer la vis "C".

## Możliwości regulacji

- a) Regulacja szczeliny:  
Poluzować wkręt "A", wkrętem "B" ustawić odpowiednią szczelinę, dokręcić wkręt "A".
- b) Regulacja głębokości:  
Poluzować wkręt "A" (1 obrót), ustawić głębokość, dokręcić wkręt "A".
- c) Regulacja wysokości:  
Poluzować wkręt "C" (1 obrót), dokonać regulacji wysokości położenia drzwi, wkręt "C" dokręcić.

