

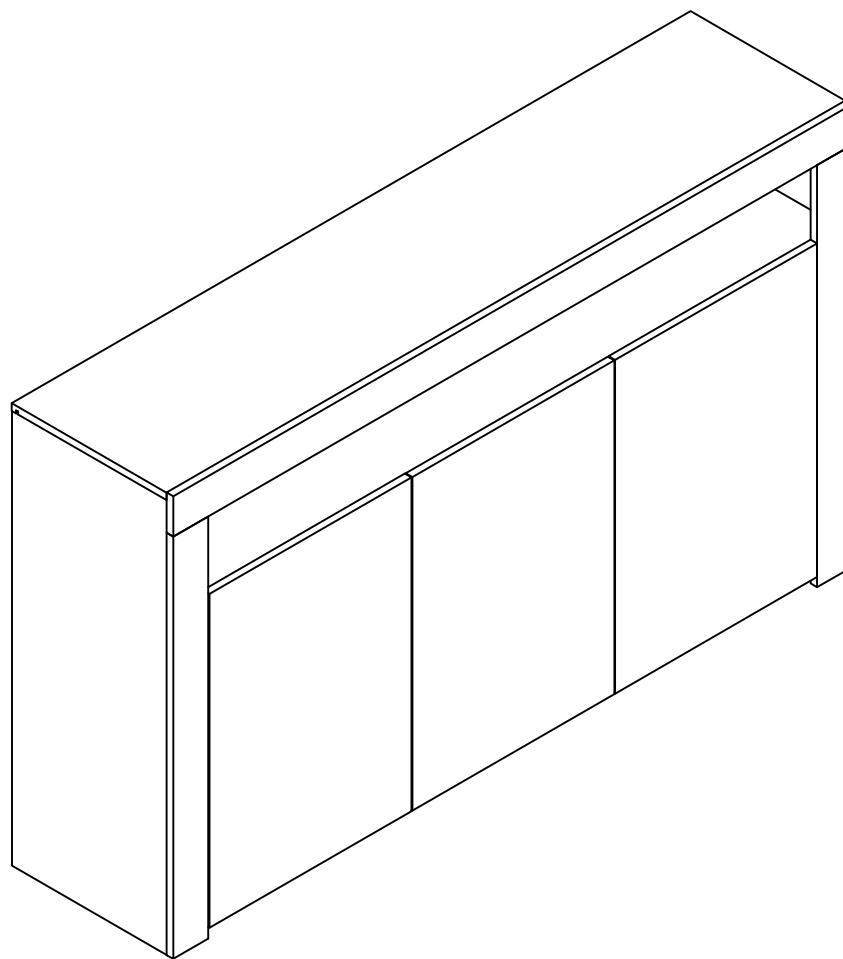

- ES: Escanea este código QR para ver las instrucciones actualizadas y posibles vídeos tutoriales.
- EN: Scan QR code for updated manual and possible tutorial videos.
- FR: Scannez ce code QR pour voir les instructions mises à jour et les vidéos possible.
- IT: Scannerizzate il codice QR per vedere le istruzioni aggiornate ed eventuali tutorial video.
- PT: Faça o scan deste código QR para obter instruções actualizadas e possíveis vídeos.
- NL: Scan de QR code voor de actuele montagehandleiding en eventuele video met uitleg.
- DE: Scannen Sie den QR-Code für die aktuelle Montageanleitung und eventuelle Video-Tutorials.

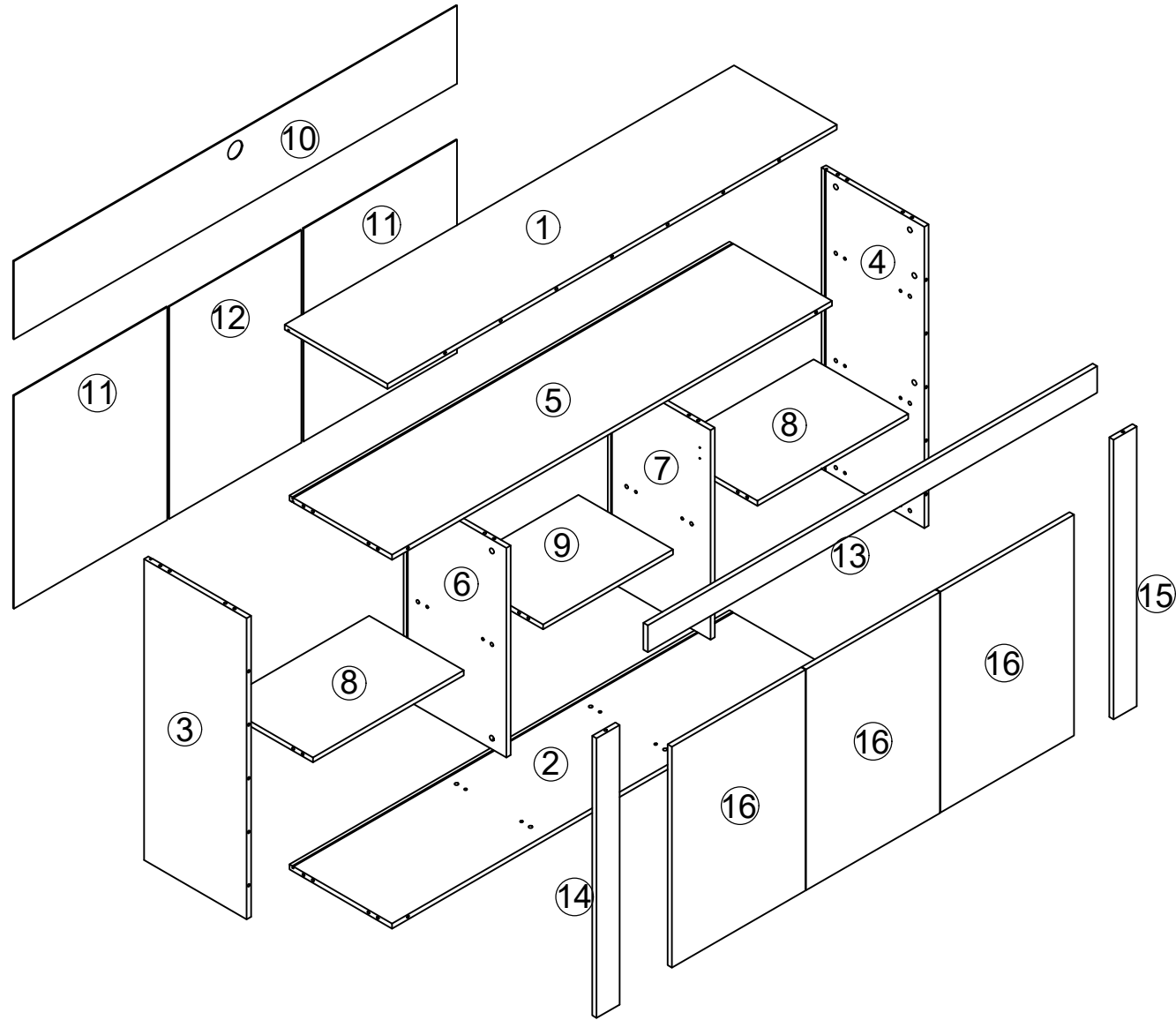



A

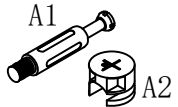

46PCS

B

8*40

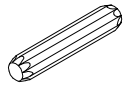

41PCS

C



4PCS

D

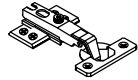

2PCS

E

3*12



12PCS

F

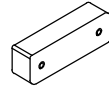

4PCS

G

3.5*14



28PCS

H

3.5*25

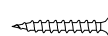

8PCS

I



12PCS

LED

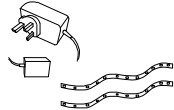

1PCS

1

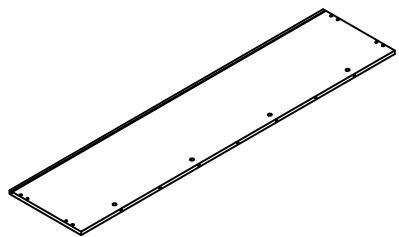

1550*354 1PS

2

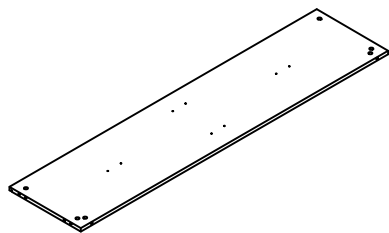

1518*354 1PS

3

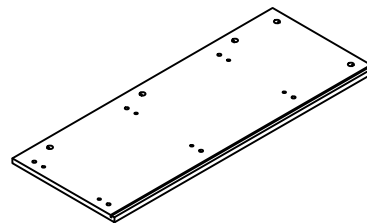

900*354 1PS

4

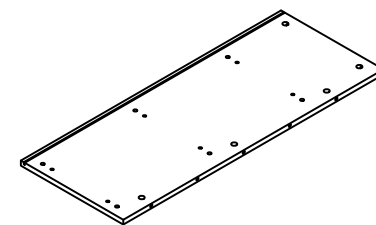

900*354 1PS

5

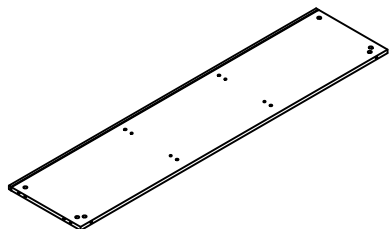

1518*354 1PS

6

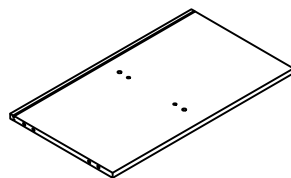

625*354 1PS

7

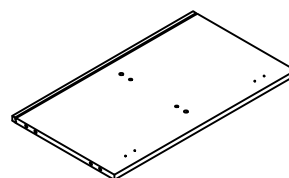

625*354 1PS

8

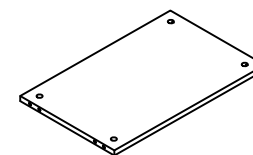

520*326 2PS

9

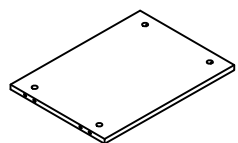

448*326 1PS

10

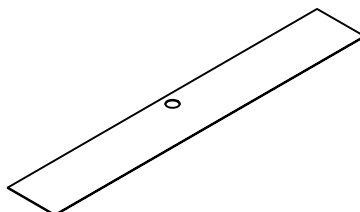

1528*233 1PS

11

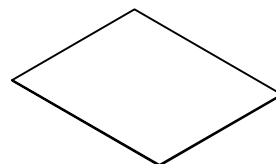

634*529 2PS

12

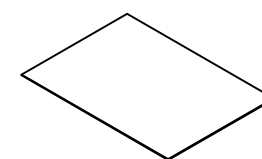

634*456 1PS

13

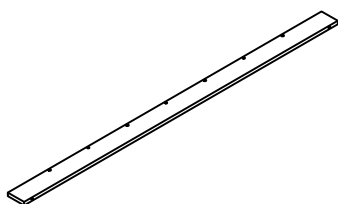

1550*80 1PS

14

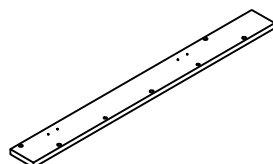

835*80 1PS

15

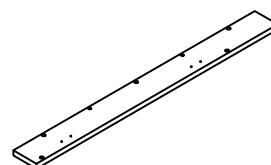

835*80 1PS

16

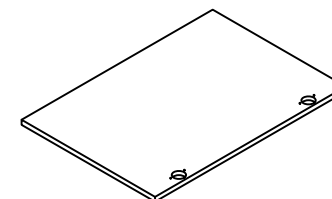

660*461 3PS

1

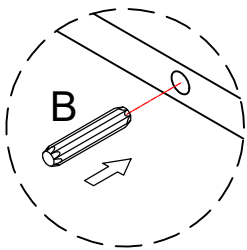
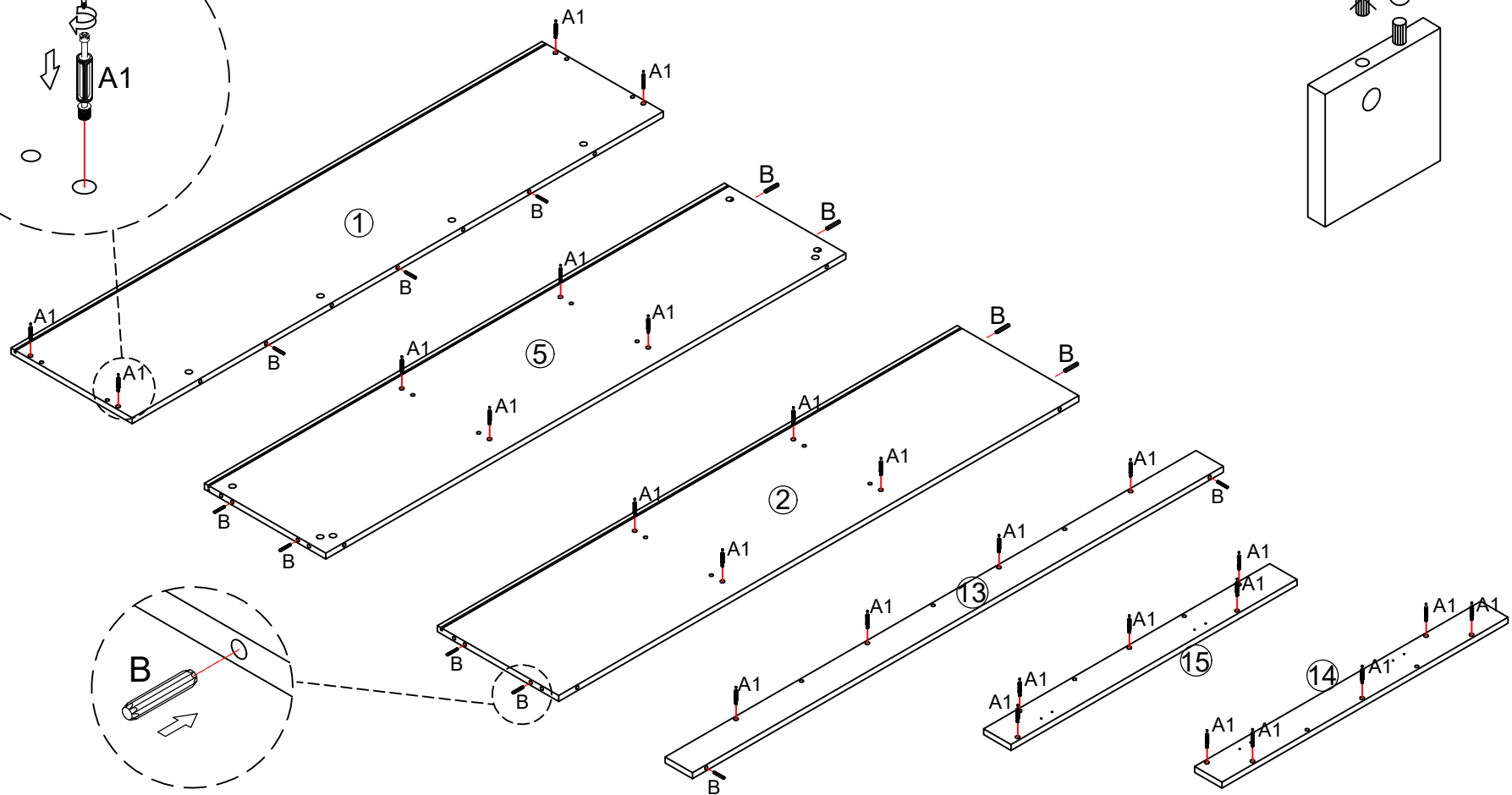
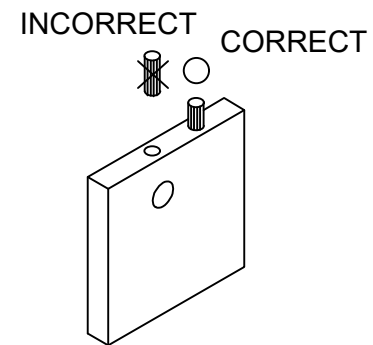
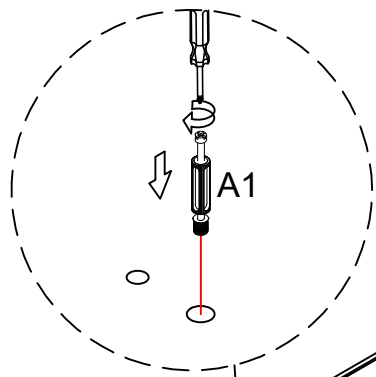

(EN)
A1 fits in board 1 2 5 13 14 15
B fits in board 1 2 5 13

(IT)
Il pezzo A1 si inserisce nei pannelli 1 2 5 13 14 15
Il pezzo B si inserisce nei pannelli 1 2 5 13

(ES)
La pieza A1 se introduce en los tableros 1 2 5 13 14 15
La pieza B se introduce en los tableros 1 2 5 13

(FR)
La pièce A1 s'insère dans les planches 1 2 5 13 14 15
La pièce B s'insère dans les planches 1 2 5 13

(NL)
A1 wordt geplaatst in de panelen 1 2 5 13 14 15
B wordt geplaatst in de panelen 1 2 5 13

(PT)
A peça A1 insere-se nas tábuas 1 2 5 13 14 15
A peça B insere-se nas tábuas 1 2 5 13

(DE)
A1 wird in die Platten 1 2 5 13 14 15 eingesetzt.
B wird in die Platten 1 2 5 13 eingesetzt



A1*26



B*13

2

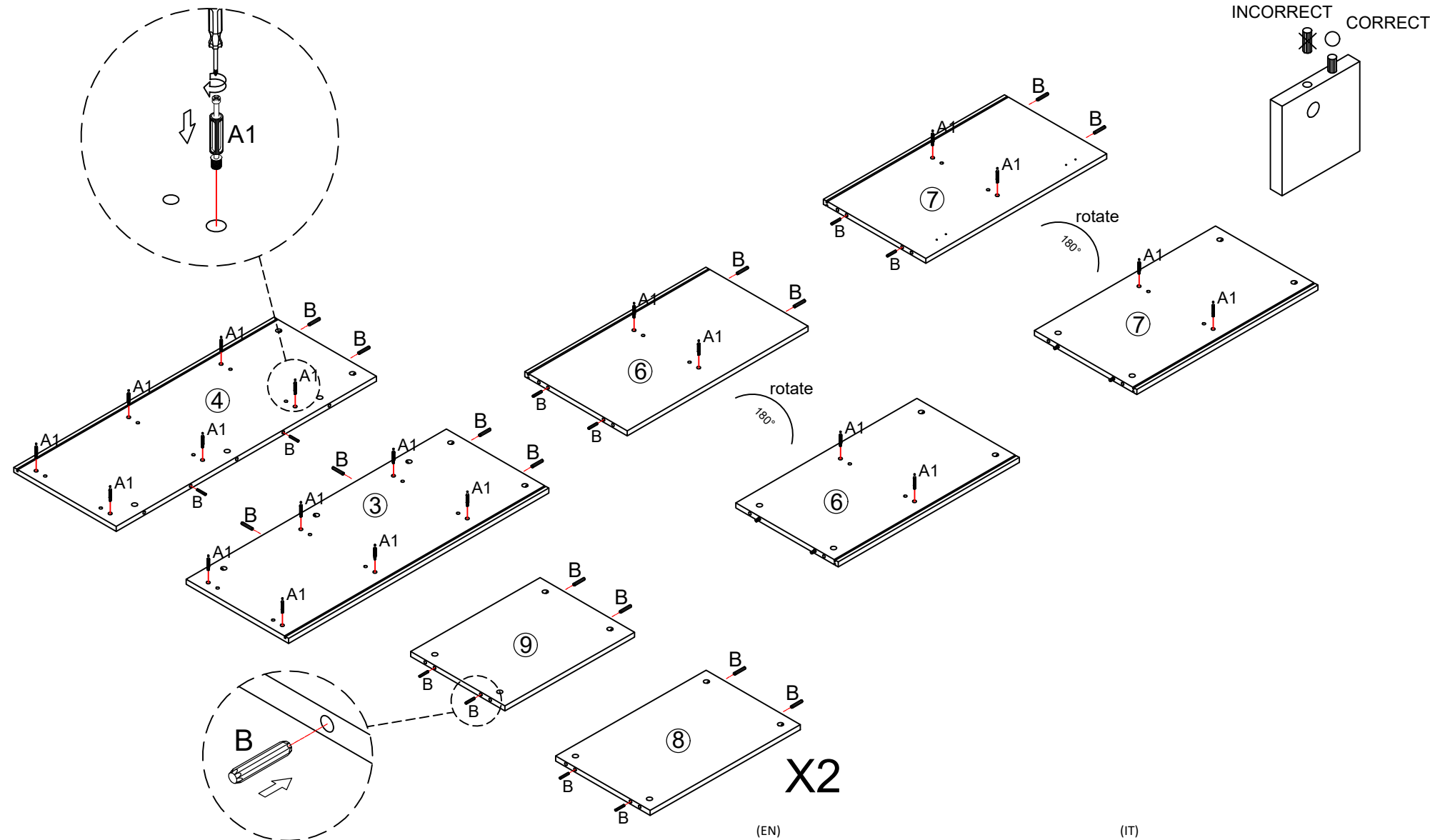

INCORRECT CORRECT

X2

(EN)
A1 fits in board 3 4 6 7
B fits in board 3 4 6 7 8 9



(IT)
Il pezzo A1 si inserisce nei pannelli 3 4 6 7
Il pezzo B si inserisce nei pannelli 3 4 6 7 8 9

(ES)
La pieza A1 se introduce en los tableros 3 4 6 7
La pieza B se introduce en los tableros 3 4 6 7 8 9

(FR)
La pièce A1 s'intère dans les planches 3 4 6 7
La pièce B s'intère dans les planches 3 4 6 7 8 9

(NL)
A1 wordt geplaatst in de panelen 3 4 6 7
B wordt geplaatst in de panelen 3 4 6 7 8 9
(DE)
A1 wird in die Platten 3 4 6 7 eingesetzt.
B wird in die Platten 3 4 6 7 8 9 eingesetzt

(PT)
A peça A1 insere-se nas tábuas 3 4 6 7
A peça B insere-se nas tábuas 3 4 6 7 8 9

	A1*20
	B*28

3

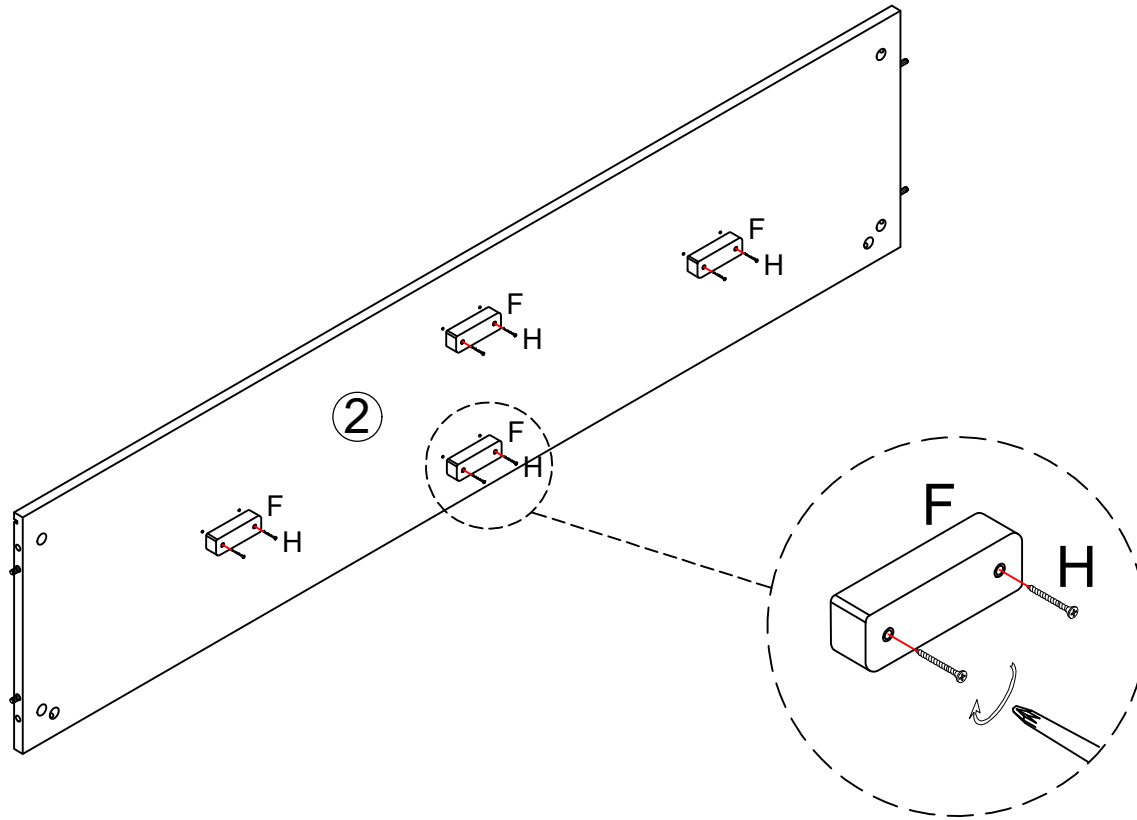

H*8



F*4

4

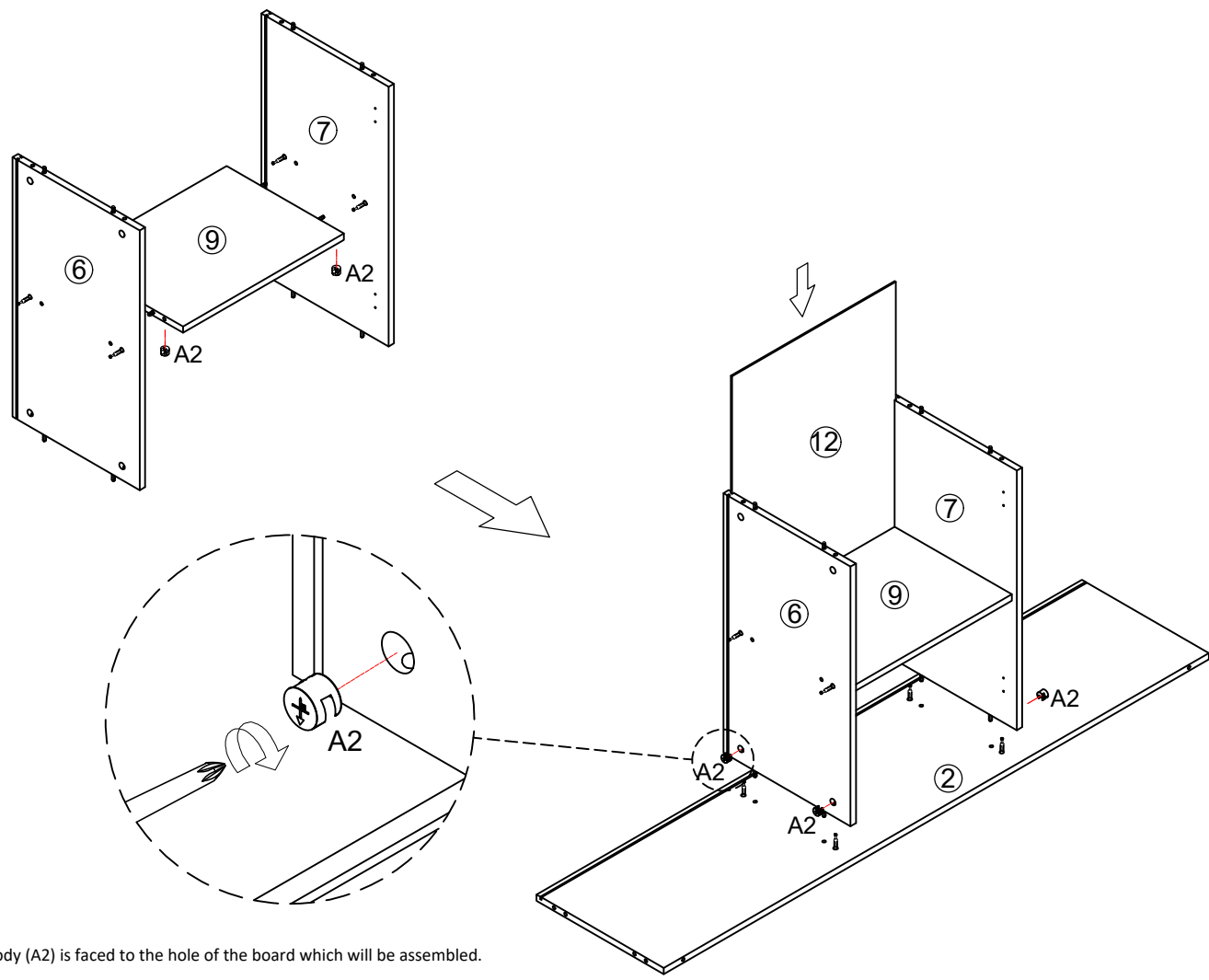

(EN)
Make sure that the arrow on the minifix body (A2) is faced to the hole of the board which will be assembled.

(ES)
Asegúrese de que la flecha de la excéntrica (pieza A2) tiene que estar orientada a la perforación del tablero al cual se va a unir.

(NL)
Let op: De pijl op de excentrische meubelverbinder (onderdeel A2) moet gericht zijn naar de boring van het paneel waarop hij moet worden bevestigd.

(DE)
Hinweis: Der Pfeil auf dem exzentrischen Möbelverbinder (A2) muss auf die Bohrung der Platte zeigen, an der er befestigt werden soll.

(PT)
Tenha certeza de que a seta do excêntrico (peça A2) deve estar orientada para a perfuração da tábua à qual vai unir-se.

(FR)
Assurez-vous que la flèche de l'excentrique (pièce A2) doit être orientée vers la perforation de la planche à laquelle elle va être jointe.

(IT)
Assicurarsi che la freccia dell'ecentrico (pezzo A2) sia orientata alla perforazione del pannello a cui andrà ad unirsi.

(EN)
A2 fits in board 6 7 9
(ES)
La pieza A2 se introduce en los tableros 6 7 9
(NL)
A2 wordt geplaatst in de panelen 6 7 9
(DE)
A2 wird in die Platten 6 7 9 eingesetzt
(IT)
Il pezzo A2 si inserisce nei pannelli 6 7 9
(FR)
La pièce A2 s'insère dans les planches 6 7 9
(PT)
A peça A2 insere-se nas tábuas 6 7 9



A2*8

5

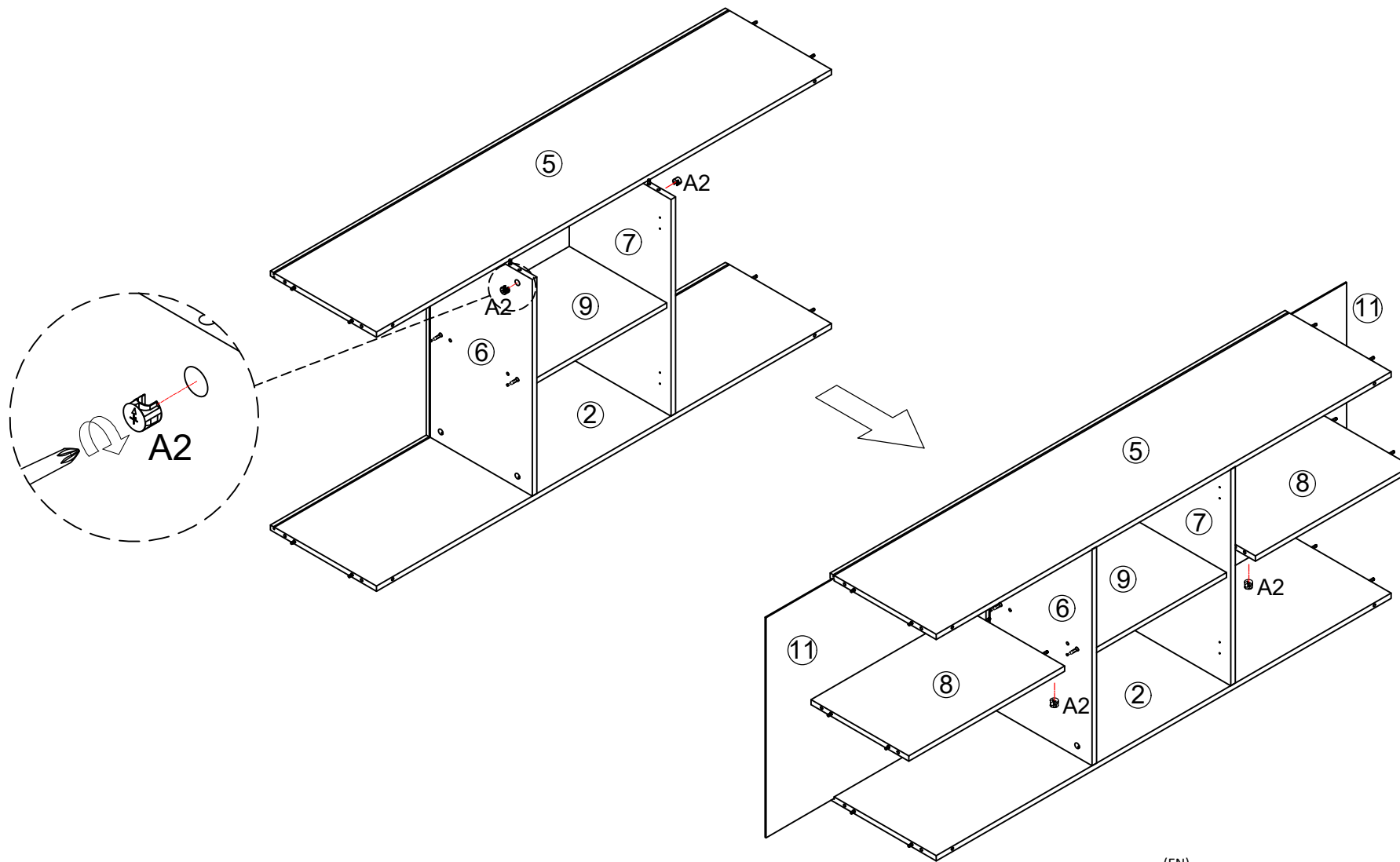

- (EN)
A2 fits in board 6 7 9
- (ES)
La pieza A2 se introduce en los tableros 6 7 9
- (NL)
A2 wordt geplaatst in de panelen 6 7 9
- (DE)
A2 wird in die Platten 6 7 9 eingesetzt
- (IT)
Il pezzo A2 si inserisce nei pannelli 6 7 9
- (FR)
La pièce A2 s'insère dans les planches 6 7 9
- (PT)
A peça A2 insere-se nas tábuas 6 7 9



A2*8

6

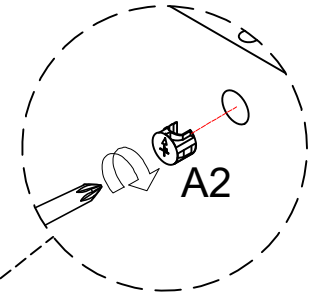
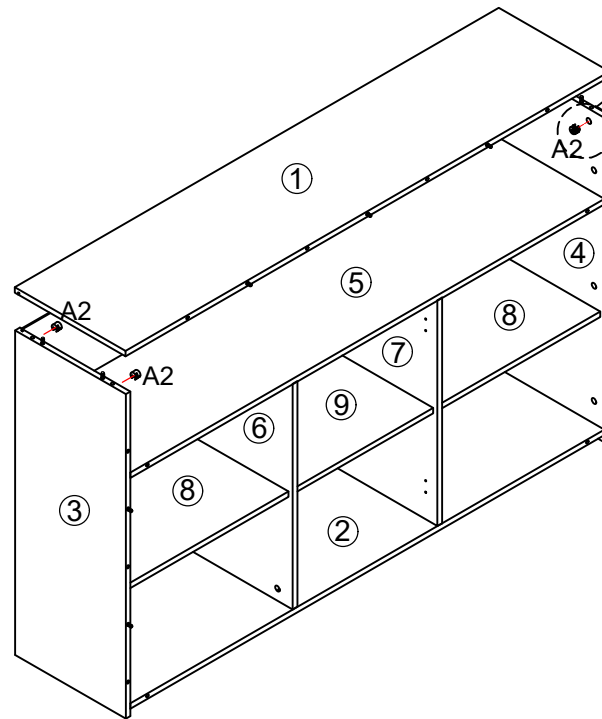
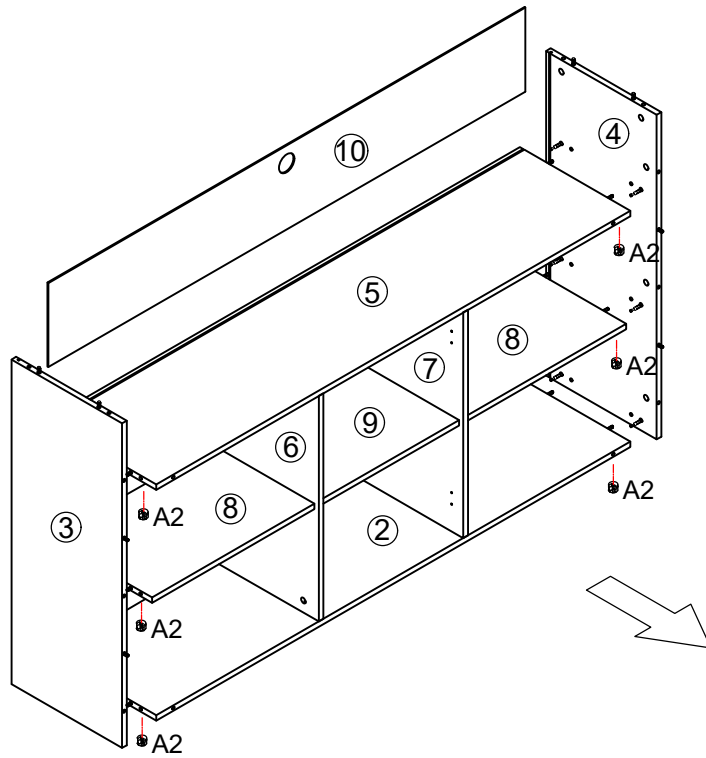





- (EN) A2 fits in board 2 3 4 5 8
- (ES) La pieza A2 se introduce en los tableros 2 3 4 5 8
- (NL) A2 wordt geplaatst in de panelen 2 3 4 5 8
- (DE) A2 wird in die Platten 2 3 4 5 8 eingesetzt
- (IT) Il pezzo A2 si inserisce nei pannelli 2 3 4 5 8
- (FR) La pièce A2 s'insère dans les planches 2 3 4 5 8
- (PT) A peça A2 insere-se nas tábuas 2 3 4 5 8

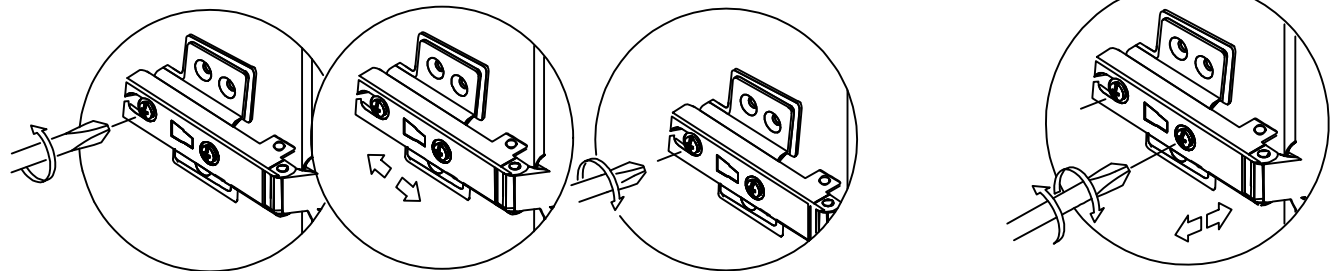
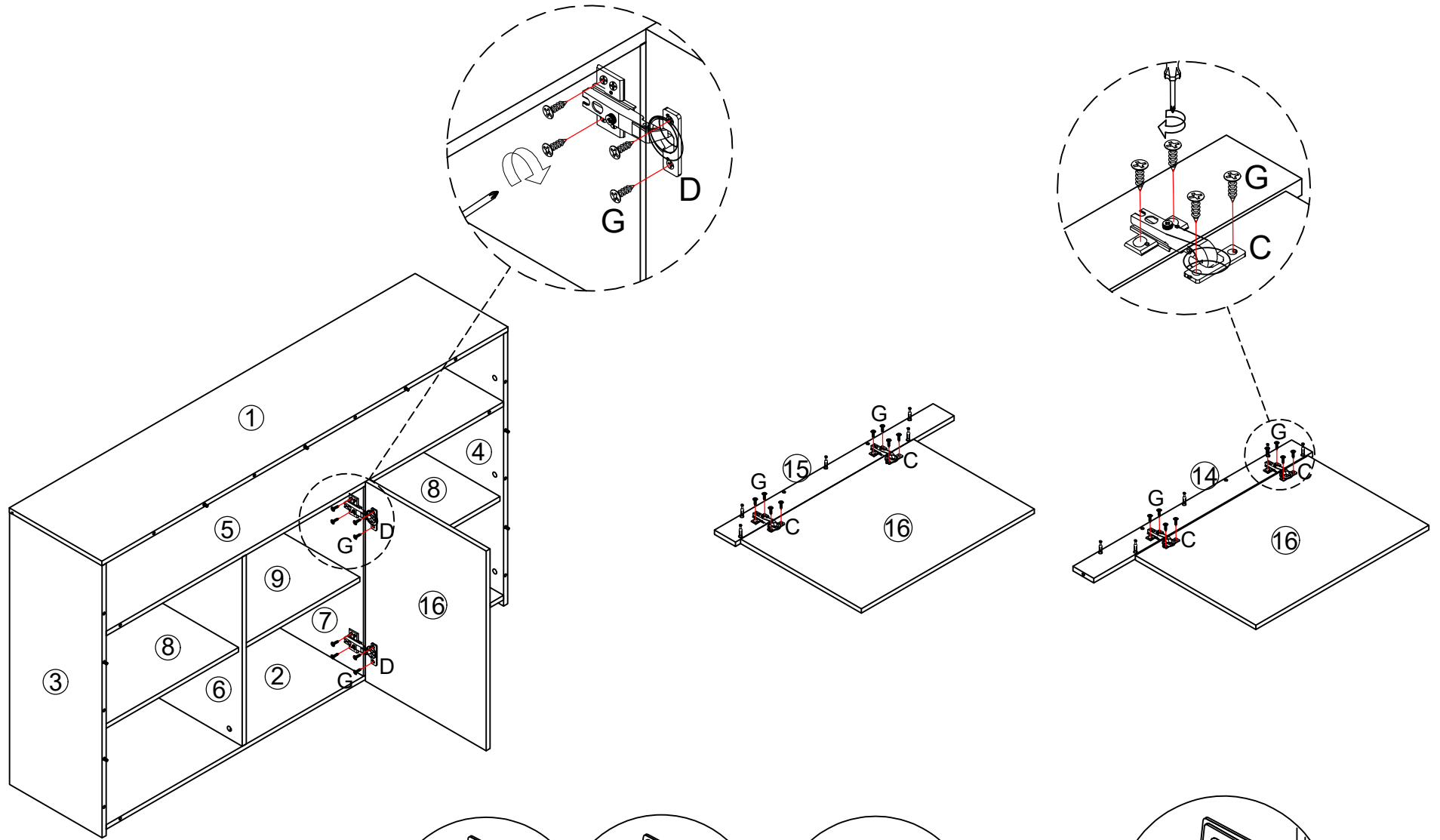

A2*16

7

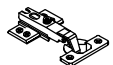

	C*4
	D*2
	G*28

8

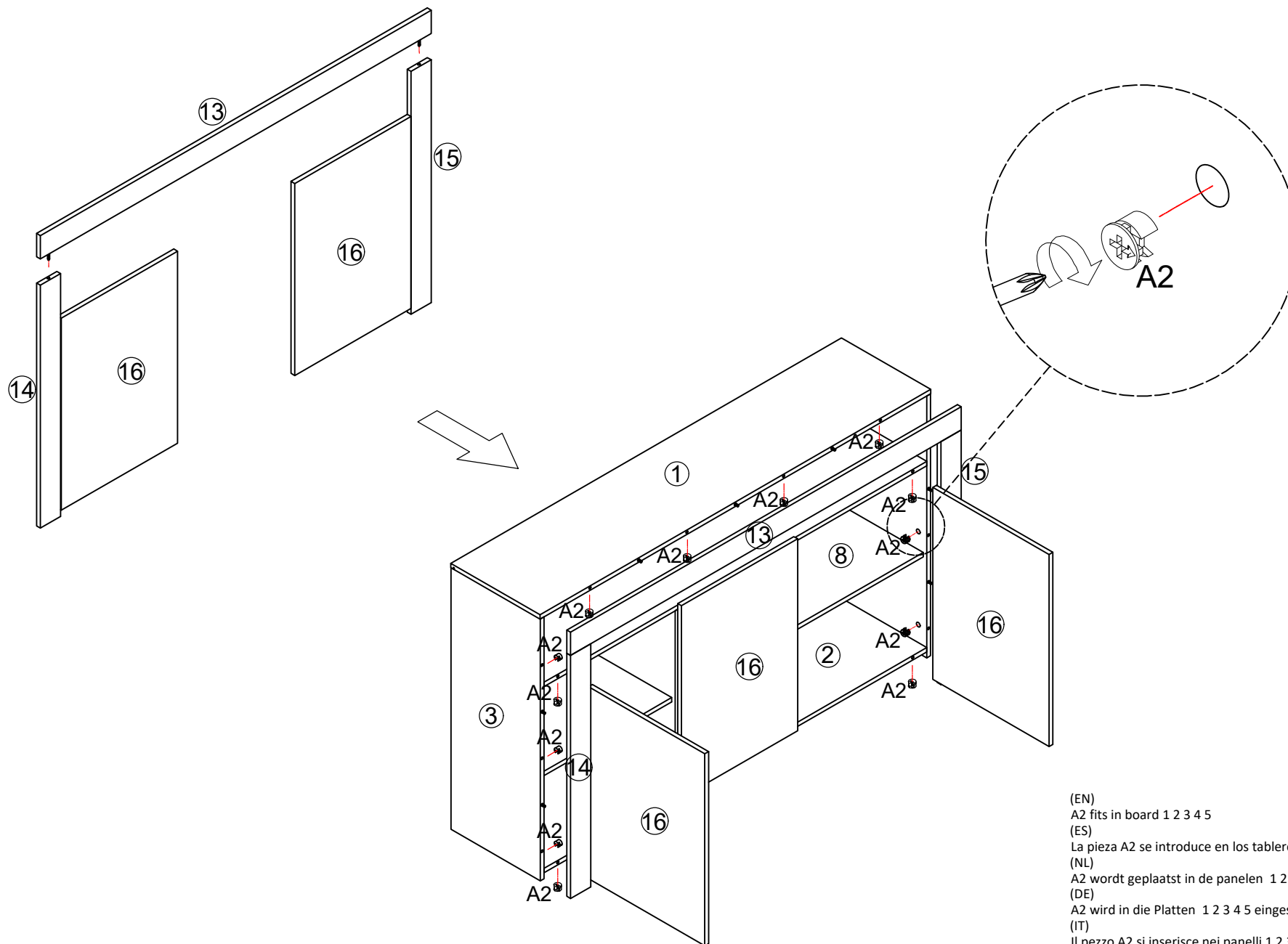

(EN)
A2 fits in board 1 2 3 4 5
(ES)
La pieza A2 se introduce en los tableros 1 2 3 4 5
(NL)
A2 wordt geplaatst in de panelen 1 2 3 4 5
(DE)
A2 wird in die Platten 1 2 3 4 5 eingesetzt
(IT)
Il pezzo A2 si inserisce nei pannelli 1 2 3 4 5
(FR)
La pièce A2 s'insère dans les planches 1 2 3 4 5
(PT)
A peça A2 insere-se nas tábuas 1 2 3 4 5



A2*14

9

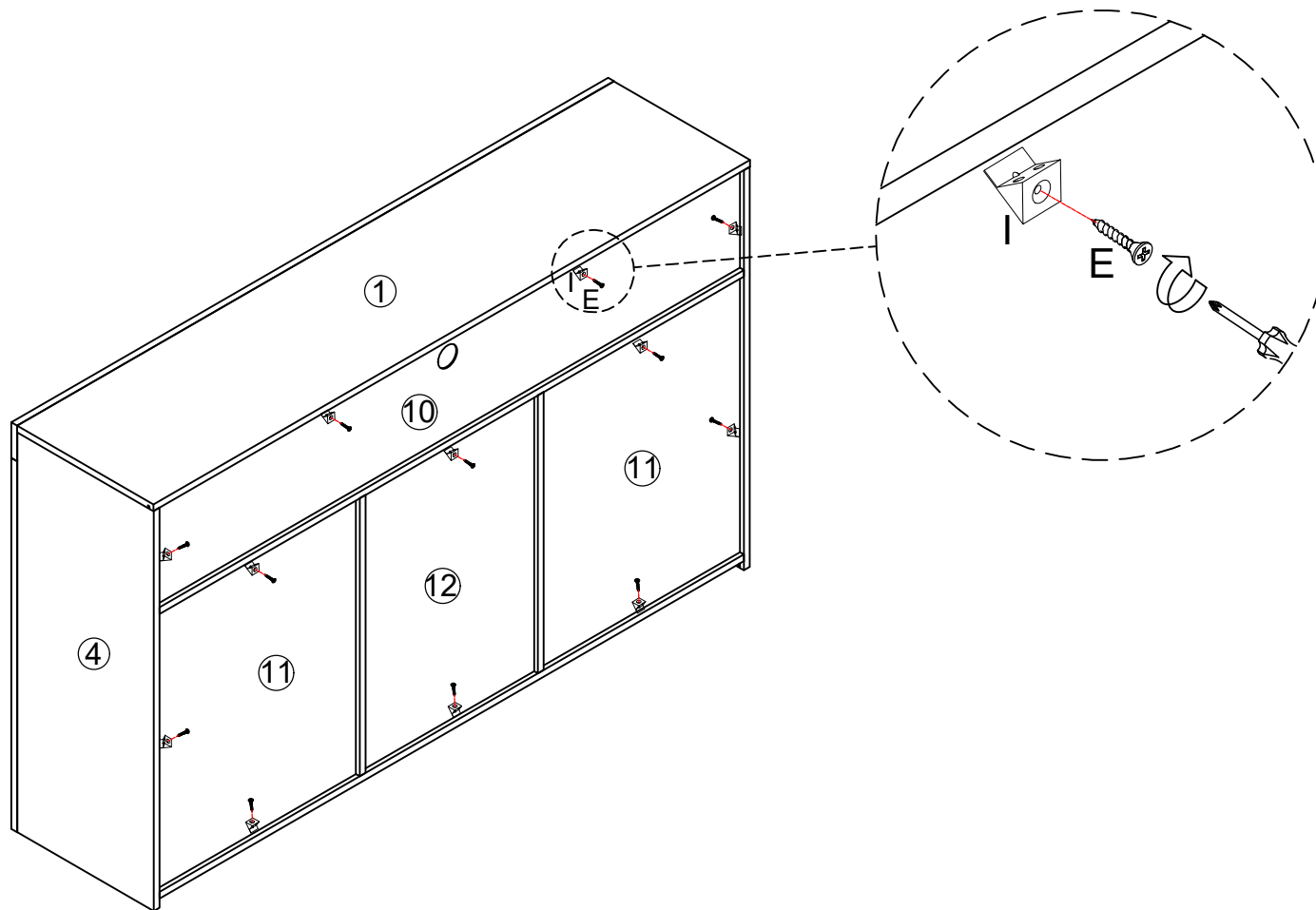

I*12



E*12

10

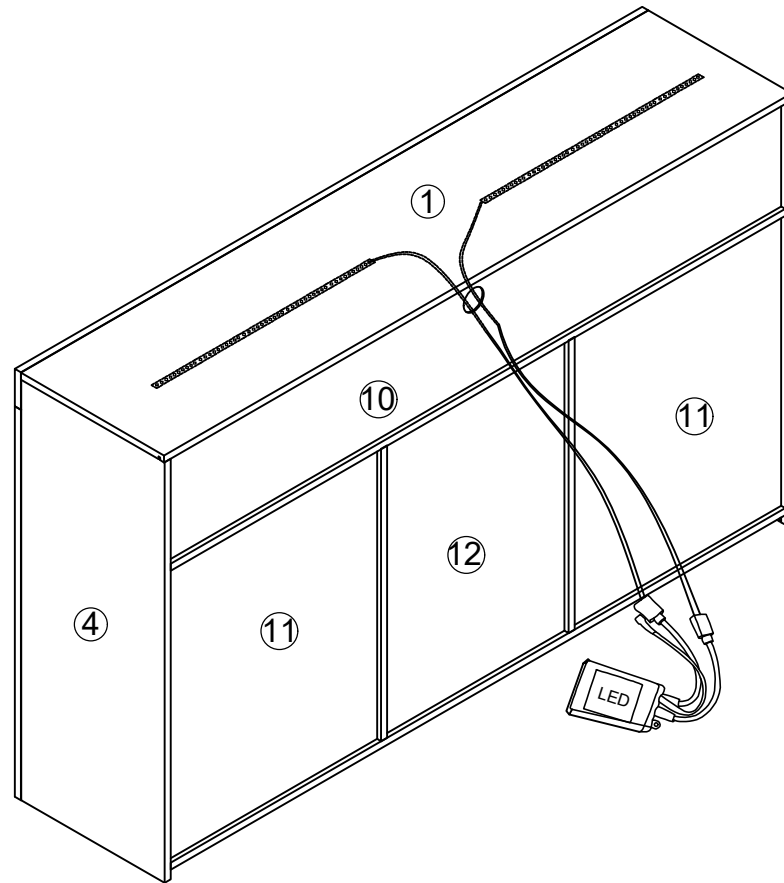
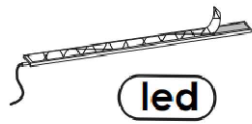

LED

LED

(EN)

1. Please check the direction of the arrows.
2. Remove all the plastic protections.
3. Do not stand too far away from the receiver, make sure there is not obstruction between the receiver and the remote control.

(ES)

1. Por favor, verifique la dirección de las flechas.
2. Retire todas las protecciones de plástico.
3. No aleje el mando del receptor y asegúrese de que no haya obstrucción entre el receptor y el mando a distancia.

(NL)

1. Controleer de richting van de pijlen.
2. Verwijder plastic beschermingen.
3. Blijf met de afstandsbediening in de buurt van de receiver en zorg dat er geen obstakels zijn tussen de receiver en de afstandsbediening.

(DE)

1. Überprüfen Sie die Richtung der Pfeile.
2. Entfernen Sie die Plastikschutzelemente.
3. Halten Sie die Fernbedienung in der Nähe des Geräts und achten Sie darauf, dass sich keine Hindernisse zwischen dem Gerät und der Fernbedienung befinden.

(FR)

1. Veuillez vérifier la direction des flèches.
2. Retirez toutes les film de protection en plastique.
3. N'éloignez pas la télécommande du récepteur et assurez-vous qu'il n'y a aucun obstacle entre le récepteur et la télécommande.

(IT)

1. Verificare la direzione delle frecce.
2. Rimuovere tutte le protezioni in plastica.
3. Non allontanare il telecomando dal ricevitore e assicurarsi che non vi siano ostacoli tra il ricevitore e il telecomando.

(PT)

1. Verifique a direção das setas.
2. Remova todas as proteções em plástico.
3. Não afaste o controle remoto do receptor e verifique-se de que não haja obstrução entre o receptor e o controle remoto.
4. Não afaste o controle remoto do receptor e tenha certeza de que não haja obstrução entre o receptor e o controle remoto.

